

ANTI-SEISMIC BRACKET



SUBMITTAL DATA

BKT2

Project _____

Location _____

Engineer _____

Contractor _____

Representative _____

Date submitted _____

Approved by _____

Date of approval _____

DESCRIPTION

Anti-seismic brackets are used to affix tanks to the floor preventing them from moving or toppling over during an earthquake. Made of steel, coated with a primer paint finish.

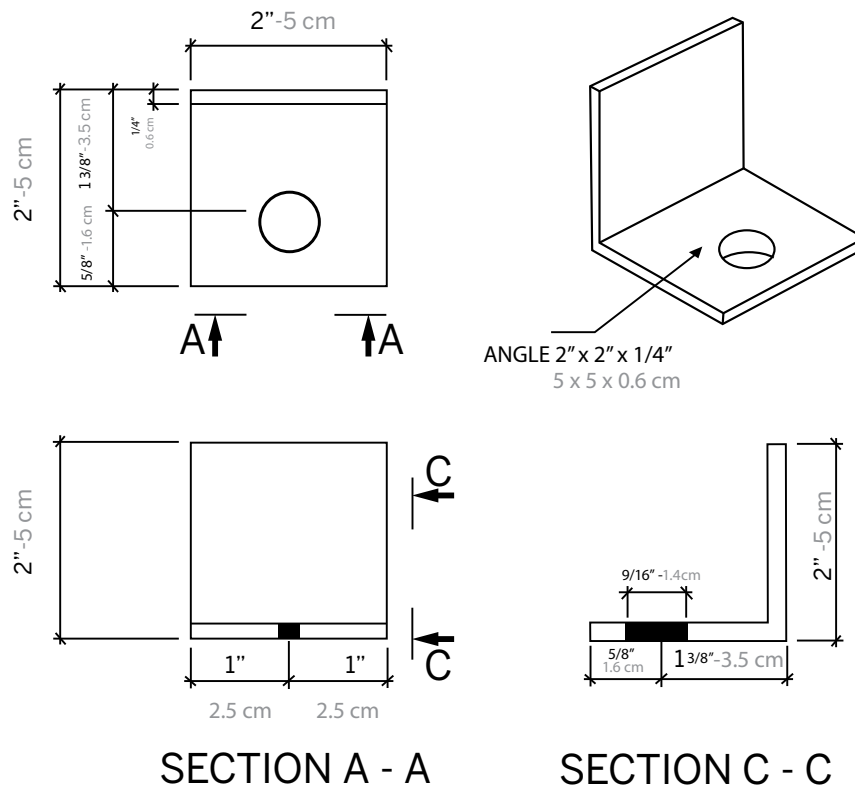

TYPICAL SPECIFICATIONS

Brackets are furnished and installed upon request by Calefactio.

Québec (Canada)

T 450 951.0818

F 450 951.2165

info@calefactio.com

calefactio.com